

XR-C4120

SERVICE MANUAL

AEP Model
UK Model

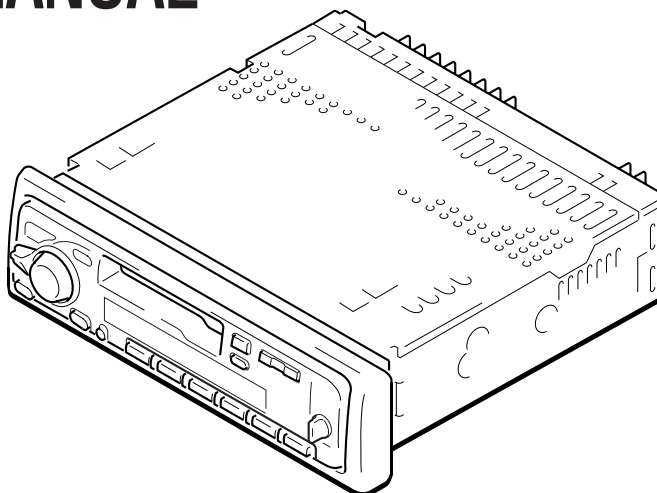

Model Name Using Similar Mechanism	XR-C4100
Tape Transport Mechanism Type	MG-25Y-136

SPECIFICATIONS

Cassette player section

Tape track	4-track 2-channel stereo
Wow and flutter	0.08 % (WRMS)
Frequency response	30 - 18,000 Hz
Signal-to-noise ratio	

Cassette type

TYPE II, IV	61 dB
TYPE I	58 dB

Tuner section

FM	
Tuning range	87.5 - 108.0 MHz
Aerial terminal	External aerial connector
Intermediate frequency	10.7 MHz
Usable sensitivity	9 dBf
Selectivity	75 dB at 400 kHz
Signal-to-noise ratio	65 dB (stereo), 68 dB (mono)
Harmonic distortion at 1 kHz	0.7 % (stereo), 0.4 % (mono)
Separation	35 dB at 1 kHz
Frequency response	30 - 15,000 Hz

MW/LW

Tuning range	MW: 531 - 1,602 kHz LW: 153 - 281 kHz
Aerial terminal	External aerial connector
Intermediate frequency	10.7 MHz/450 kHz
Sensitivity	MW: 30 μ V LW: 50 μ V

Power amplifier section

Outputs	Speaker outputs (sure seal connectors)
Speaker impedance	4 - 8 ohms
Maximum power output	40 W \times 4 (at 4 ohms)

General

Outputs	Audio output Power aerial relay control lead Power amplifier control lead Telephone ATT control lead
Tone controls	Bass \pm 8 dB at 400 Hz Treble \pm 8 dB at 10 kHz
Power requirements	12 V DC car battery (negative earth)
Dimensions	Approx. 188 \times 58 \times 181 mm (w/h/d)
Mounting dimensions	Approx. 182 \times 53 \times 164 mm (w/h/d)
Mass	Approx. 1.2 kg
Supplied accessories	Rotary commander (1) Parts for installation and connections (1 set) Front panel case (1)

Design and specifications are subject to change without notice.

FM/MW/LW CASSETTE CAR STEREO



SONY®

6-3. SCHEMATIC DIAGRAM - MAIN Board (1/2) - • See page 18 for Waveforms. • See page 29 for IC Block Diagrams.

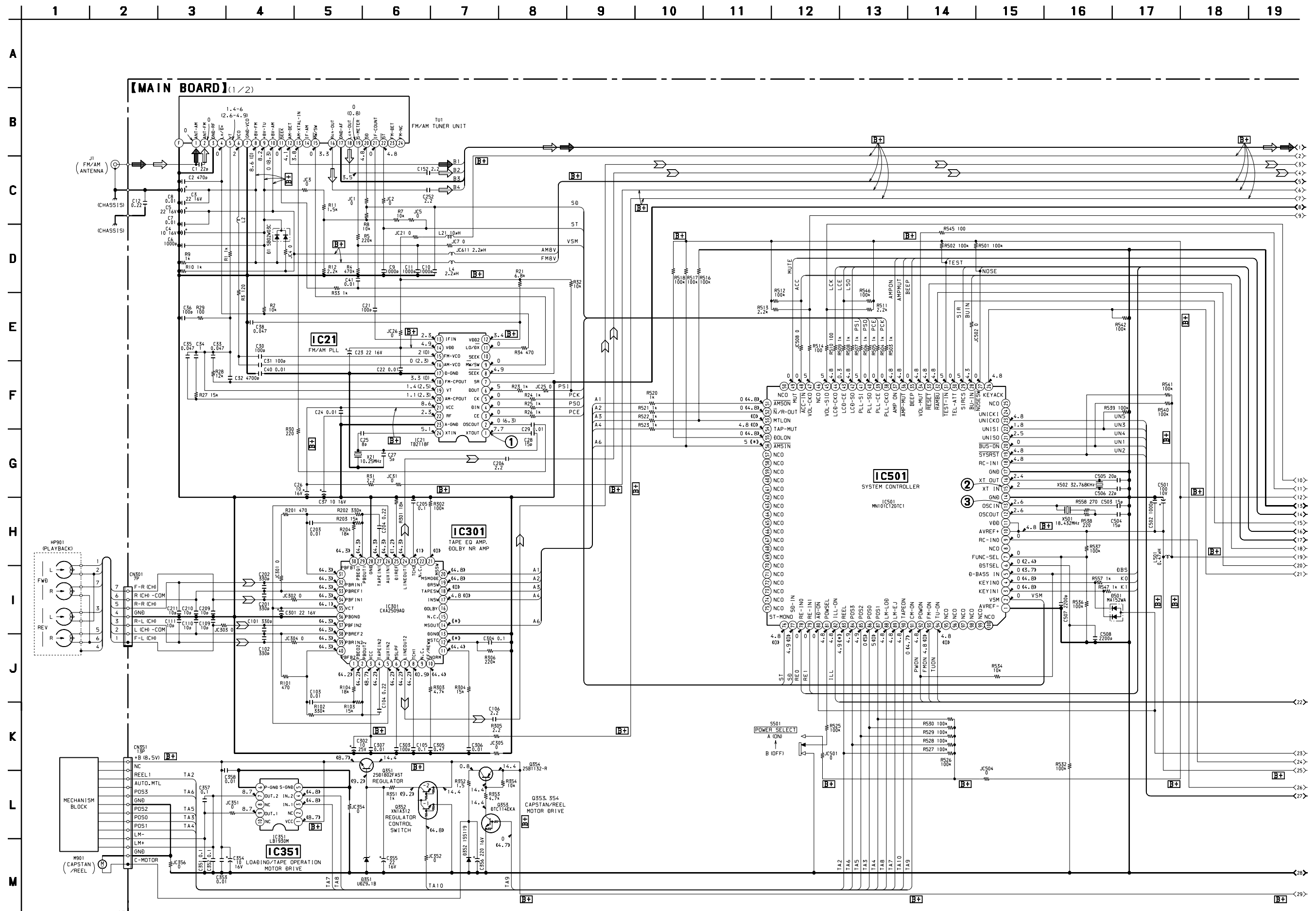

6-4. SCHEMATIC DIAGRAM - MAIN Board (2/2) - • See page 30 for IC Block Diagrams.

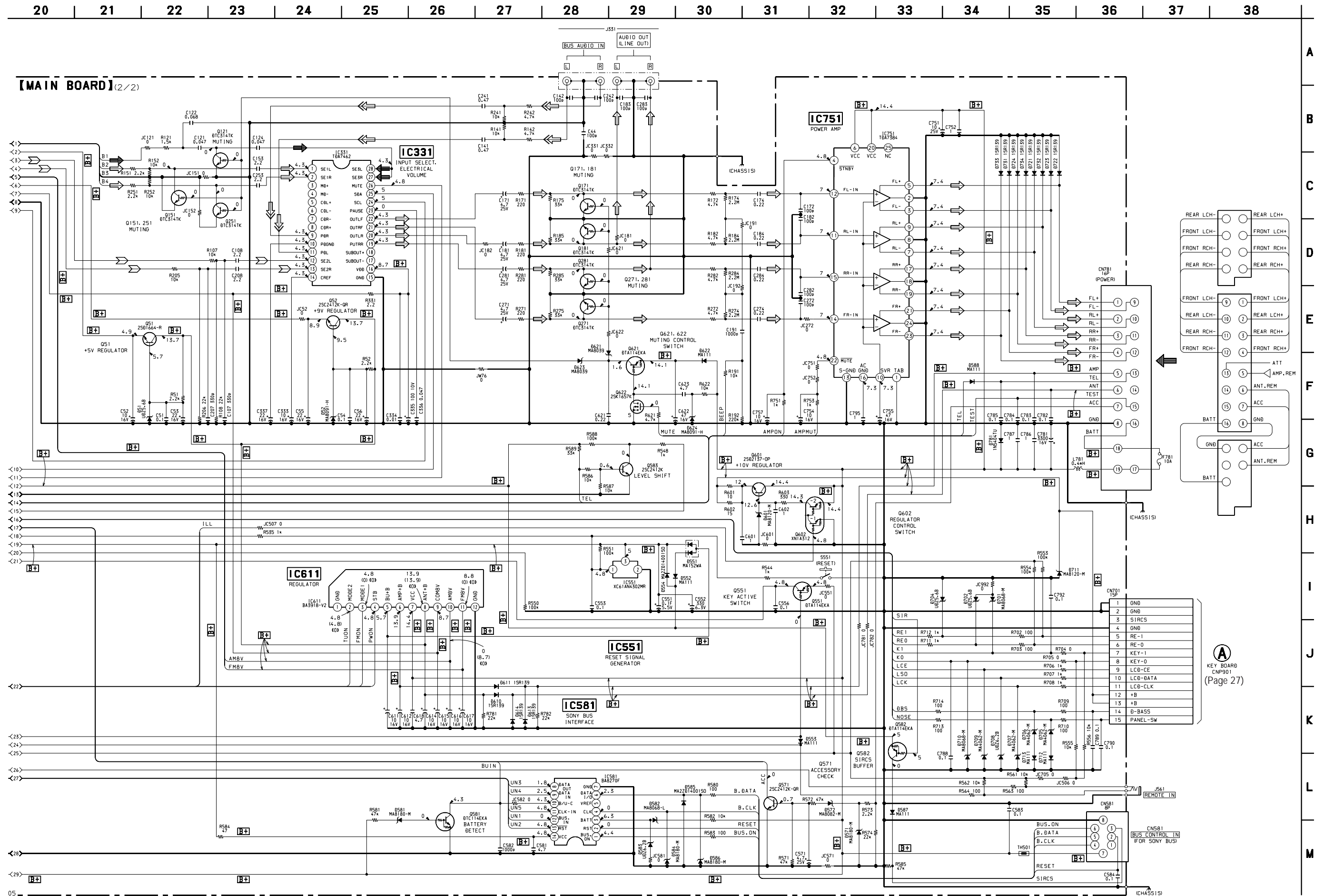

6-6. SCHEMATIC DIAGRAM – KEY Board – • See page 18 for Waveform.

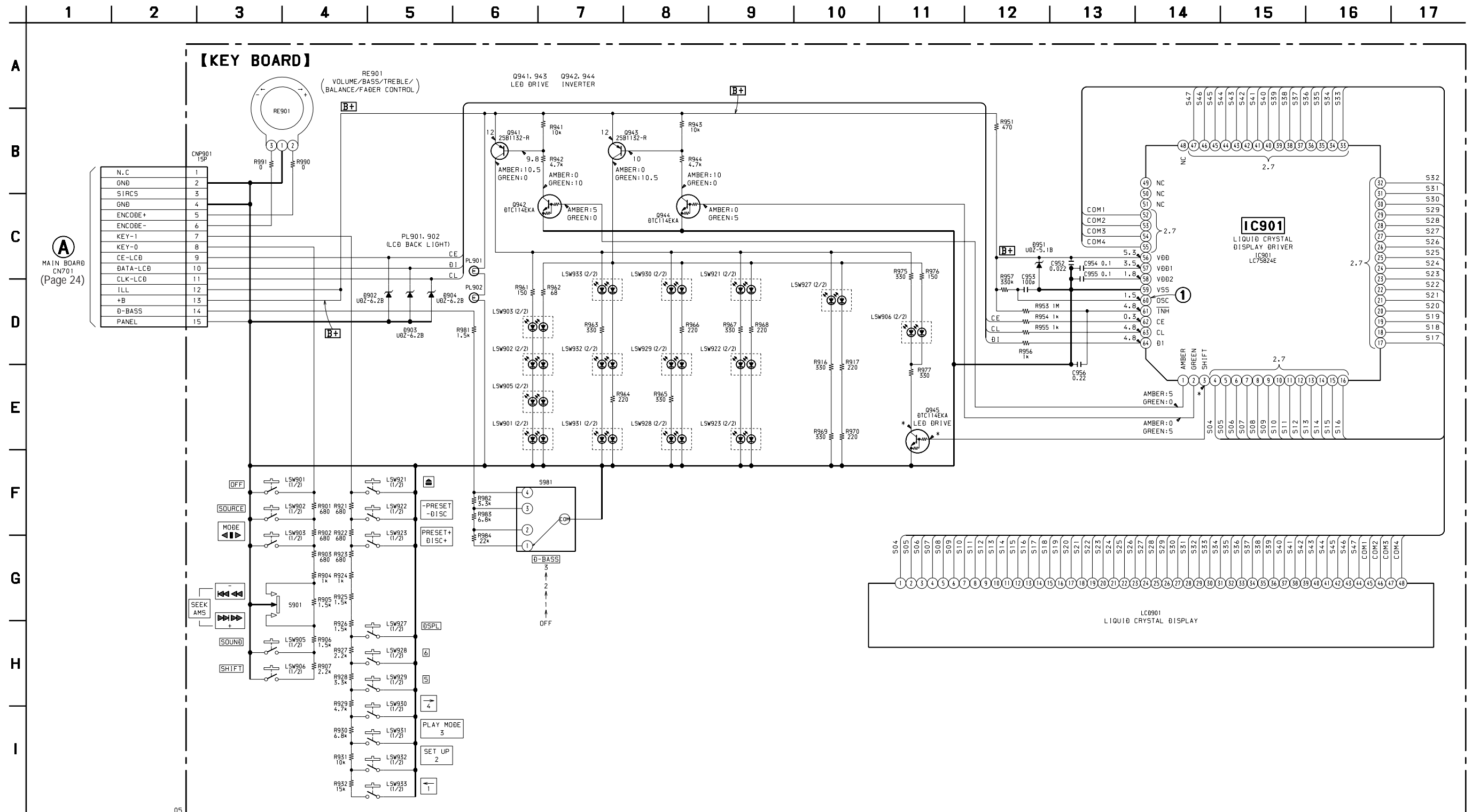

• IC Block Diagrams
– MAIN Board –

IC21 TB2118F-EL-S

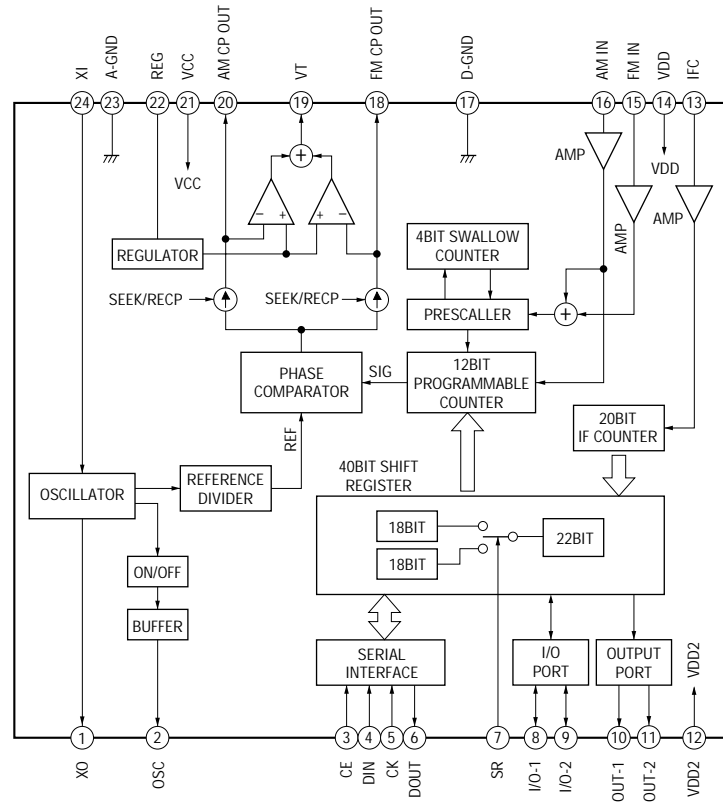

IC301 CXA2509AQ-T4

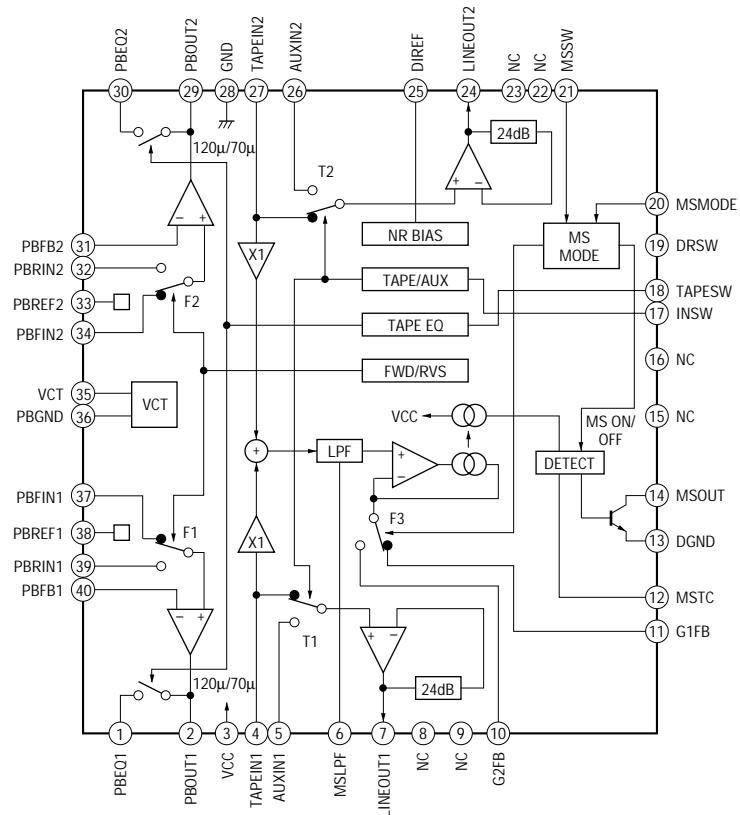

IC331 TDA7462D

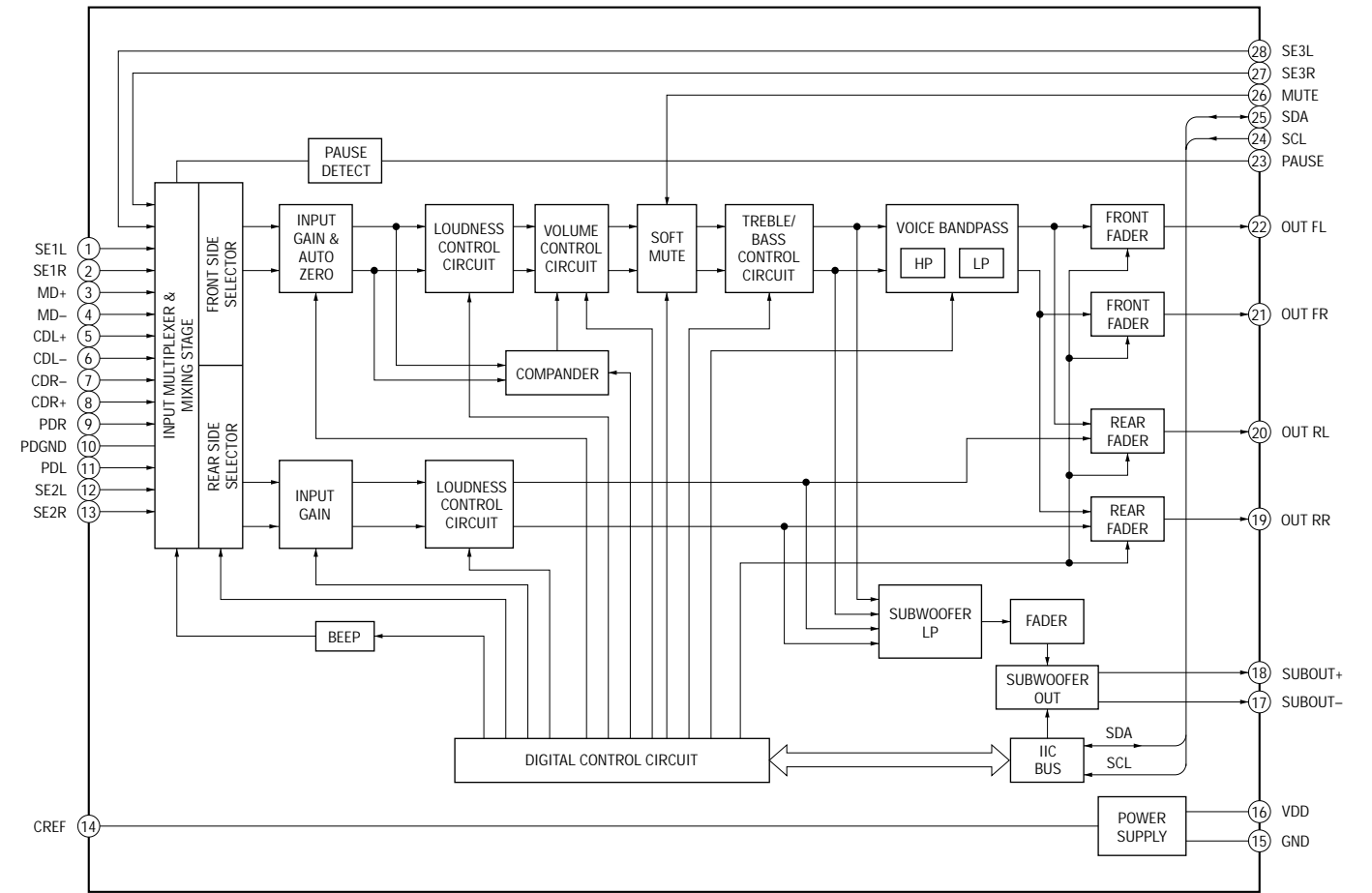

IC351 LB1930M-TLM

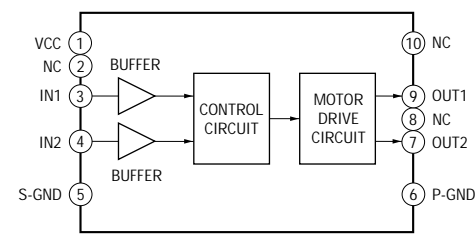

IC611 BA3918-V2

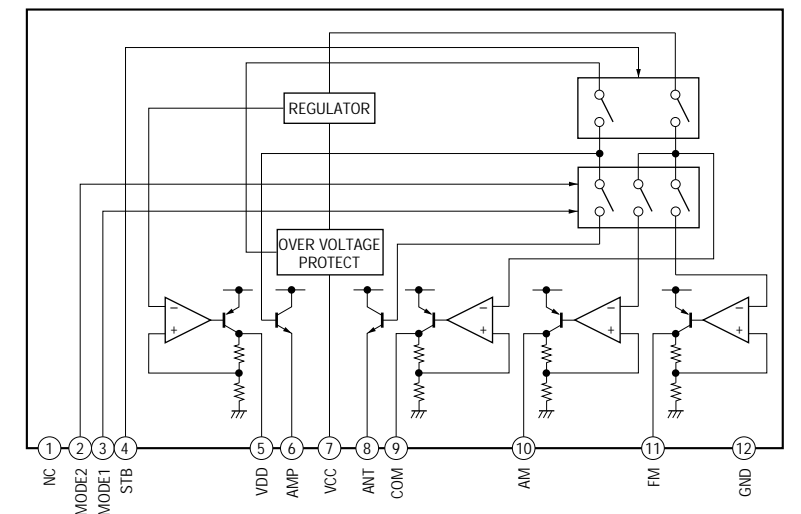

IC581 BA8270F-E2

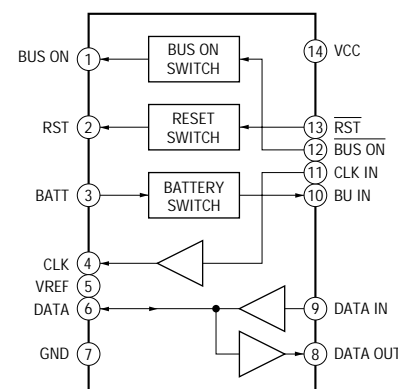

6-7. IC PIN FUNCTION DESCRIPTION

• MAIN BOARD IC501 MN101C12GTC1 (SYSTEM CONTROLLER)

Pin No.	Pin Name	I/O	Function
1	AVREF-	I	Reference voltage (0V) input terminal (for A/D converter)
2	VSM	I	FM and AM signal meter voltage detection input from the FM/AM tuner unit (TU1) (A/D input)
3	KEYIN1	I	Key input terminal (A/D input) (LSW921 to LSW923, LSW927 to LSW933) ▲, PRESET DISC -/+, DSPL, 6, 5, 4 →, 3 PLAY MODE, 2 SET UP, 1 ← keys input
4	KEYIN0	I	Key input terminal (A/D input) (LSW901 to LSW903, S901, LSW905, LSW906) OFF, SOURCE, MODE ◀▶, SEEK/AMS ◀◀ ◀◀ - ▶▶ ▶▶ +, SOUND, SHIFT keys input
5	D-BASS IN	I	D-BASS switch (S981) input terminal (A/D input)
6	DSTSEL	I	Destination setting terminal (fixed at “L” in this set)
7	FUNC-SEL	I	Setting terminal for the function select (fixed at center voltage in this set)
8	NCO	O	Not used (open)
9	RC-IN0	I	Rotary remote commander key input terminal (A/D input)
10	AVREF+	I	Reference voltage (+5V) input terminal (for A/D converter)
11	VDD	—	Power supply terminal (+5V)
12	OSC OUT	O	Main system clock output terminal (18.432 MHz)
13	OSC IN	I	Main system clock input terminal (18.432 MHz)
14	GND	—	Ground terminal
15	XT IN	I	Sub system clock input terminal (32.768 kHz)
16	XT OUT	O	Sub system clock output terminal (32.768 kHz)
17	GND	—	Ground terminal
18	RC-IN1	I	Rotary remote commander shift key input terminal “L”: shift
19	<u>SYRST</u>	O	Reset signal output to the SONY bus interface (IC581) “L”: reset
20	<u>BUS-ON</u>	O	Bus on/off control signal output to the SONY bus interface (IC581) “L”: bus on
21	UNISO	O	Serial data output to the SONY bus interface (IC581)
22	UNISI	I	Serial data input from the SONY bus interface (IC581)
23	UNICKO	O	Serial data transfer clock signal output to the SONY bus interface (IC581)
24	UNICKI	I	Serial data reading clock signal input for the SONY bus interface Not used (open)
25	NCO	O	Not used (open)
26	KEYACK	I	Input of acknowledge signal for the key entry Acknowledge signal is input to accept function and eject keys in the power off status On at input of “H”
27	<u>NOSESW</u>	I	Front panel block remove/attach detection signal input terminal “L”: front panel is attached
28	BU-IN	I	Battery detect signal input from the SONY bus interface (IC581) and battery detect circuit “L” is input at low voltage
29	SIRCS	I	Sircs remote control signal input terminal Not used (fixed at “L”)
30	TEL-ATT	I	Telephone muting signal input terminal At input of “H”, the signal is attenuated by -20 dB
31	<u>TEST-IN</u>	I	Setting terminal for the test mode “L”: test mode, Normally: fixed at “H”
32	<u>RAMBU</u>	I	Internal RAM reset detection signal input terminal Input terminal to check that RAM data are not destroyed due to low voltage This checking is made within 100 msec after reset Fixed at “L” in this set
33	<u>RESET</u>	I	System reset signal input from the reset signal generator (IC551) and reset switch (S551) “L”: reset “L” is input for several 100 msec after power on, then it changes to “H”
34	VOL-MUT	O	Muting control signal output to the electrical volume (IC331) Volume minimum: “∞” output (“H” active)
35	BEEP	O	Beep sound drive signal output terminal
36	<u>AMP-MUT</u>	O	Muting on/off control signal output to the power amplifier (IC751) “L”: muting on

Pin No.	Pin Name	I/O	Function
37	AMP ON	O	Standby on/off control signal output to the power amplifier (IC751) “L”: standby mode, “H”: amp on
38	PLL-CKO	O	PLL serial data transfer clock signal output to the FM/AM PLL (IC21)
39	PLL-CE	O	PLL chip enable signal output to the FM/AM PLL (IC21) “H” active
40	PLL-SO	O	PLL serial data output to the FM/AM PLL (IC21)
41	PLL-SI	I	PLL serial data input from the FM/AM PLL (IC21)
42	LCD-SO	O	Serial data output to the liquid crystal display driver (IC901)
43	LCD-CE	O	Chip enable signal output to the liquid crystal display driver (IC901) “H” active
44	LCD-CKO	O	Serial data transfer clock signal output to the liquid crystal display driver (IC901)
45	VOL-SIO	I/O	Two-way data bus with the electrical volume (IC331)
46	NCO	O	Not used (open)
47	VOL-CKO	O	Bus clock signal output to the electrical volume (IC331)
48	$\overline{\text{ACC-IN}}$	I	Accessory detect signal input terminal “L”: accessory on
49	MUT	O	Audio line muting on/off control signal output terminal “H”: muting on
50	NCO	O	Not used (open)
51	$\overline{\text{AMSON}}$	O	Tape auto music sensor control signal output to the CXA2509AQ (IC301) “L” is output to lower the gain for audio level at FF/REW mode
52	$\overline{\text{N/R-OUT}}$	O	Forward/reverse direction control signal output to the CXA2509AQ (IC301) “L”: forward direction, “H”: reverse direction
53	MTLON	I/O	METAL control in/out terminal At initial mode: valid/invalid selection input of METAL function (valid at “L” input) At normal mode: METAL on/off control signal output to the CXA2509AQ (IC301) (METAL on at “H” output)
54	TAPE-MUT	O	Tape muting on/off control signal output to the CXA2509AQ (IC301) “H”: muting on Active at ATA, FF/REW mode
55	DOLON	I/O	Dolby control in/out terminal At initial mode: valid/invalid selection input of dolby function (valid at “L” input) At normal mode: dolby on/off control signal output terminal (dolby on at “H” output) Not used this function (fixed at “H”)
56	$\overline{\text{AMSIN}}$	I	Whether a music is present or not from CXA2509AQ (IC301) is detected at auto music sensor “L”: music is present, “H”: music is not present
57 to 75	NCO	O	Not used (open)
76	ST-MONO	I/O	FM stereo broadcasting detection signal input from the FM/AM tuner unit (TU1), or forced monaural control signal output to the FM/AM tuner unit (TU1) “L” is input in the FM stereo mode, or “L” is output in the forced monaural mode
77	SD-IN	I	Station detector detect input from the FM/AM tuner unit (TU1) Stop level for SEEK, BTM, etc. is determined SD is present at input of “H”
78	RE-IN0	I	Dial pulse input of the rotary encoder (RE900) (for VOLUME/BASS/TREBLE/BALANCE/FADER control)
79	RE-IN1	I	
80	$\overline{\text{AD-ON}}$	O	A/D converter power control signal output terminal When the KEYACK (pin ②) that controls reference voltage power for key A/D conversion input is active, “L” is output from this terminal to enable the input
81	POWSEL	I	Power select switch (S501) input terminal “L”: off (halt mode), “H”: on (operation mode)
82	ILL-ON	O	Power on/off control signal output of the illumination LED and liquid crystal display driver (IC901) “H”: power on Depends on initial setting of power select switch (S501) Power select switch (S501) on: “H” output at the accessory on Power select switch (S501) off: “H” output at the power on
83	REEL	I	Rotation detect signal input from supply reel sensor and take-up reel sensor on the deck mechanism

Pin No.	Pin Name	I/O	Function
84	POS3	I	Tape position (EJECT/FF/REW/REV/FWD mode) detect input from the tape operation switch on the deck mechanism POS3: "L": REV and EJECT mode, "H": others mode POS2: "L": REW mode, "H": others mode POS0: "L": EJECT mode, "H": others mode POS1: "L": FF and FWD mode, "H": others mode
85	POS2	I	
86	POS0	I	
87	POS1	I	
88	LM-LOD	O	Motor drive signal output to the loading/tape operation motor drive (IC351) "H" active (For the loading direction and forward side operation) *1
89	LM-EJ	O	Motor drive signal output to the loading/tape operation motor drive (IC351) "H" active (For the eject direction and reverse side operation) *1
90	TAPEON	O	Tape system power supply on/off control signal output terminal "H": tape on
91	CM-ON	O	Capstan/reel motor (M901) drive signal output terminal "H": motor on
92	POWON	O	Main system power supply on/off control signal output to the BA3918 (IC611) "H": power on
93	FM-ON	O	FM system power supply on/off control signal output to the BA3918 (IC611) "L": AM power on, "H": FM power on
94	TU-ON	O	Tuner system power supply on/off control signal output to the BA3918 (IC611) "H": tuner power on
95 to 100	NCO	O	Not used (open)

*1 Loading/tape operation motor control

Terminal \ Mode	STOP	LOADING/ FORWARD	EJECT/ REVERSE	BRAKE
LM-LOD (pin ⑧)	"L"	"H"	"L"	"H"
LM-EJ (pin ⑨)	"L"	"L"	"H"	"H"